

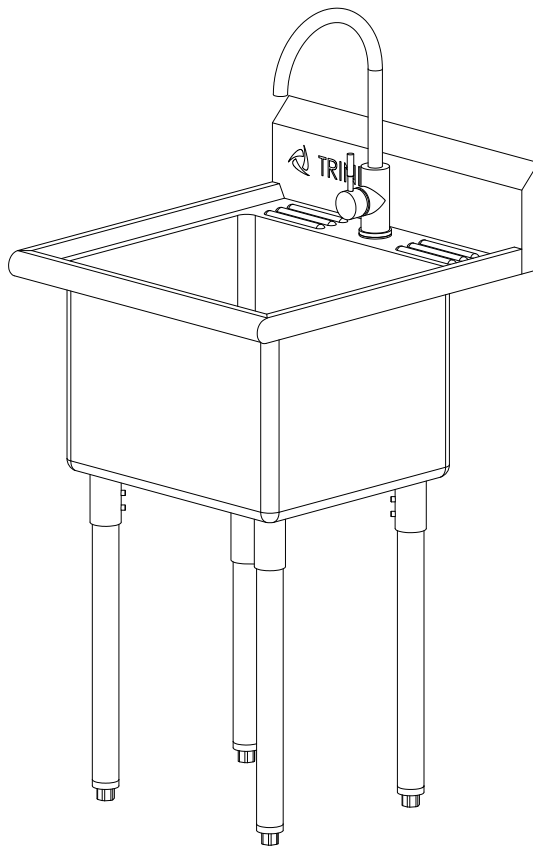

OWNER'S MANUAL



TRINITY BASICS STAINLESS STEEL UTILITY SINK W/ FAUCET
Model # THA-0307

PARTS LIST

Your TRINITY Basics Stainless Steel Utility Sink w/Faucet should include the following parts. Please inspect box contents to ensure you have received all components.

If you are missing any parts, need assistance with assembly or have questions, please contact TRINITY Customer Service: 800.985.5506 or customerservice@trinityii.com. Parts can also be requested online at www.trinityii.com (Help & More, Contact Us).

A Phillips head screwdriver is required, and a pipe wrench is recommended.

A

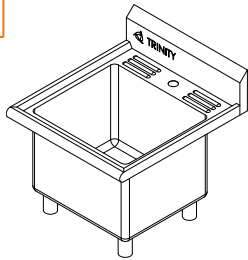

SINK (1)

B



LEG (4)
W/ FEET LEVELER

C

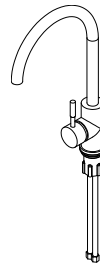

FAUCET ASSEMBLY (1)
W/ HOSES

D



DRAIN ASSEMBLY (1)

E



HEX SCREW (8) + (2) extra
(8) are pre-installed on sink,
(2) extras are packed in the hardware bag

F



SCREW CAP (8)

G



HEX KEY (1)

H

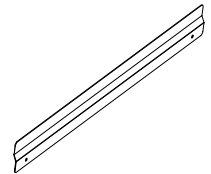

BRACKET (1)

I



MOUNTING SCREW (2)

J

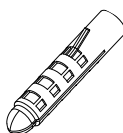

ANCHOR (2)

ASSEMBLY INSTRUCTIONS

STEP 1

Lay SINK (A) upside-down. Unscrew HEX SCREWS (E) that are pre-installed on Leg Collars on bottom of SINK (A) until LEGS (B) can be fully inserted.

Insert LEGS (B) into Leg Collars. Tighten both HEX SCREWS (E) on each Leg Collar with HEX KEY (G). Place a SCREW CAP (F) over each HEX SCREW (E).

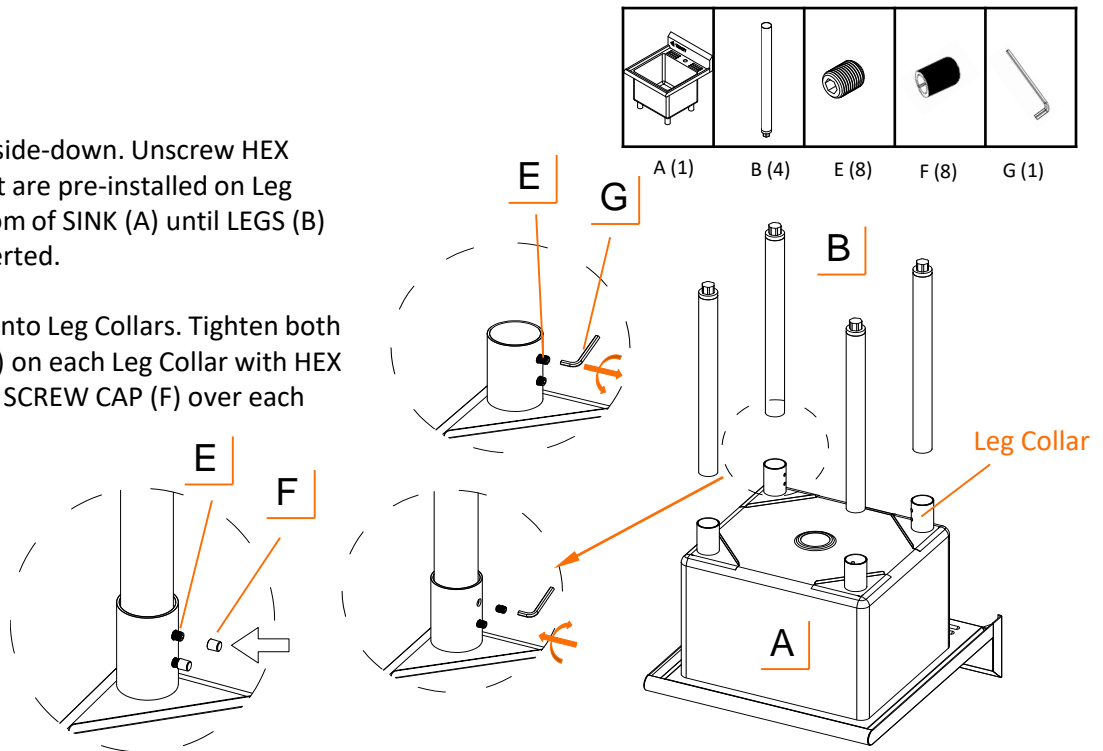

STEP 2

Carefully turn sink right-side up, standing it upright.

Unscrew large 3-3/8" Nut from bottom of DRAIN ASSEMBLY (D). Insert Drain through opening at bottom of SINK (A) from inside.

From under SINK (A), first slide Rubber Washer on, then Paper Gasket, then screw large 3-3/8" Nut back on tightly. If necessary use a pipe wrench to tighten.

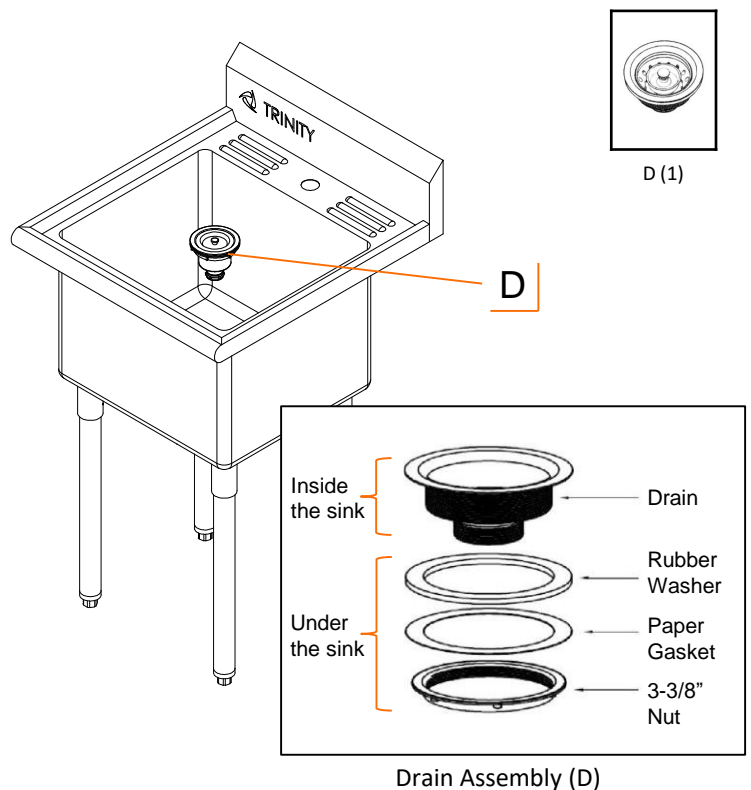

ASSEMBLY INSTRUCTIONS

STEP 3

Unscrew each screw securing Lock Nut to bottom of FAUCET ASSEMBLY (C) and remove Lock Nut w/Screws, Metal Washer and Rubber Gasket.

From top side, insert FAUCET ASSEMBLY (C) through hole. Make sure Metal Base is on top of SINK (A). Align faucet handle facing towards front of SINK (A). From under SINK (A), first slide on Rubber Gasket, then Metal Washer, and lastly, screw on Lock Nut w/Screws pointed upward. Tighten Lock Nut as much as you can by hand and tighten screws with a screw driver.

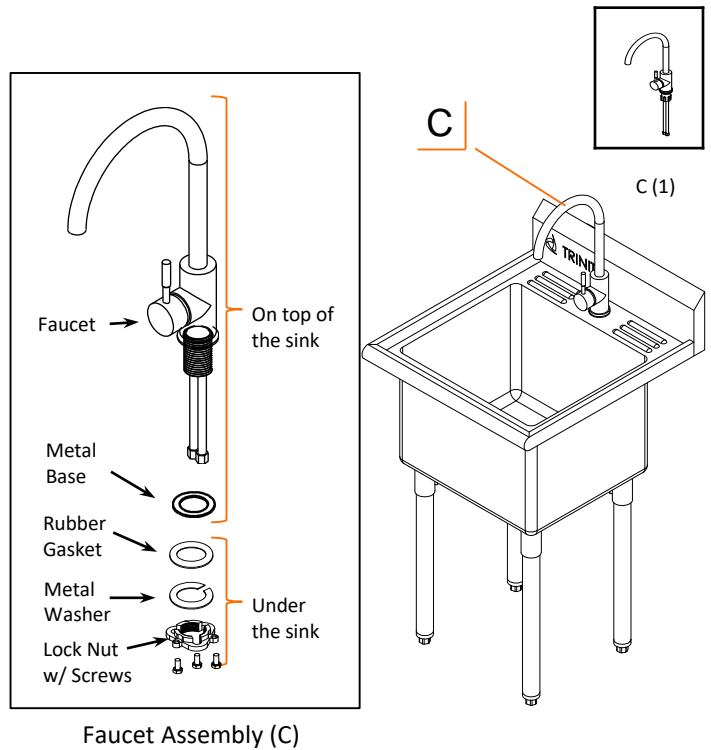

STEP 4

Carefully move sink against wall at your desired location. If needed, use a pencil to mark off mounting height of BRACKET (H).

Position BRACKET (H) on wall, marking off fastening location on wall through holes on BRACKET (H). Drill holes in marked locations. Insert ANCHOR (J) completely into each drilled hole. Fasten MOUNTING SCREWS (I) through these holes into wall or anchors tightly with a screwdriver.

Slightly lift sink and hook flange of sink over BRACKET (H). Adjust Feet Levelers to ensure sink is stable and level. Connect Hoses and Drain to plumbing system.

Note: Bracket is to prevent sink tipping, NOT for mounting sink to a wall. Do NOT mount sink to a wall without legs.

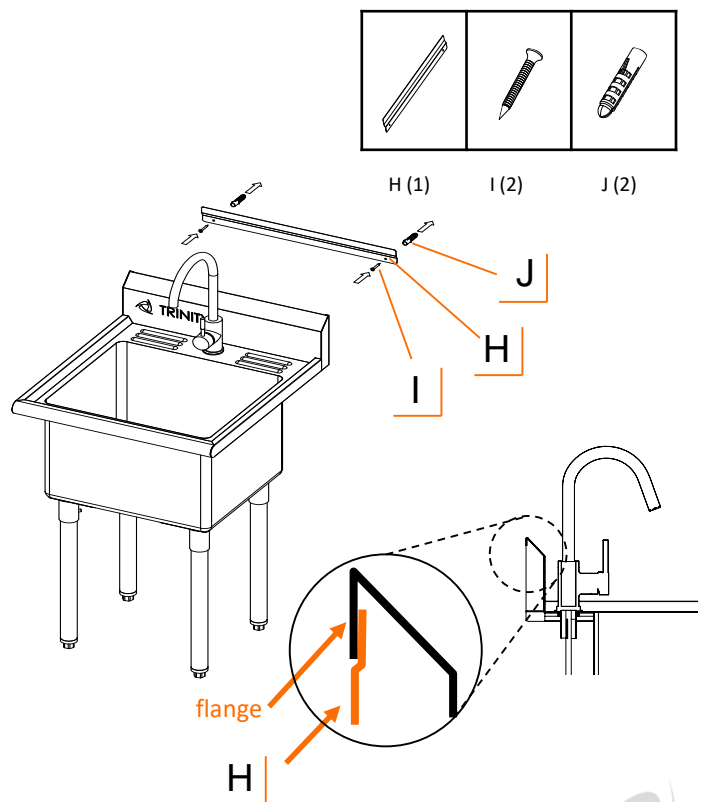

SERVICE PARTS LIST

TRINITY Customer Service provides the following replacement parts:

	Part Number	Description	Part Number	Description	
1)	XBS-19-007-1600	Bracket	7)	XGR-98-005-3775	Feet Leveler
2)	XGR-01-032-0440	Anchor	8)	XSV-01-034-0808	Hex Screw
3)	XSV-01-033-0440	Mounting Screw	9)	XXX-97-001-0001	Hex Key
4)	XBS-18-023-1816	Sink	10)	XBS-02-003-0002	Drain Assembly
5)	XBK-23-005-0815	Screw Cap	11)	CGL-02-009-0003	Faucet Assembly
6)	XGL-04-045-1950	Leg			

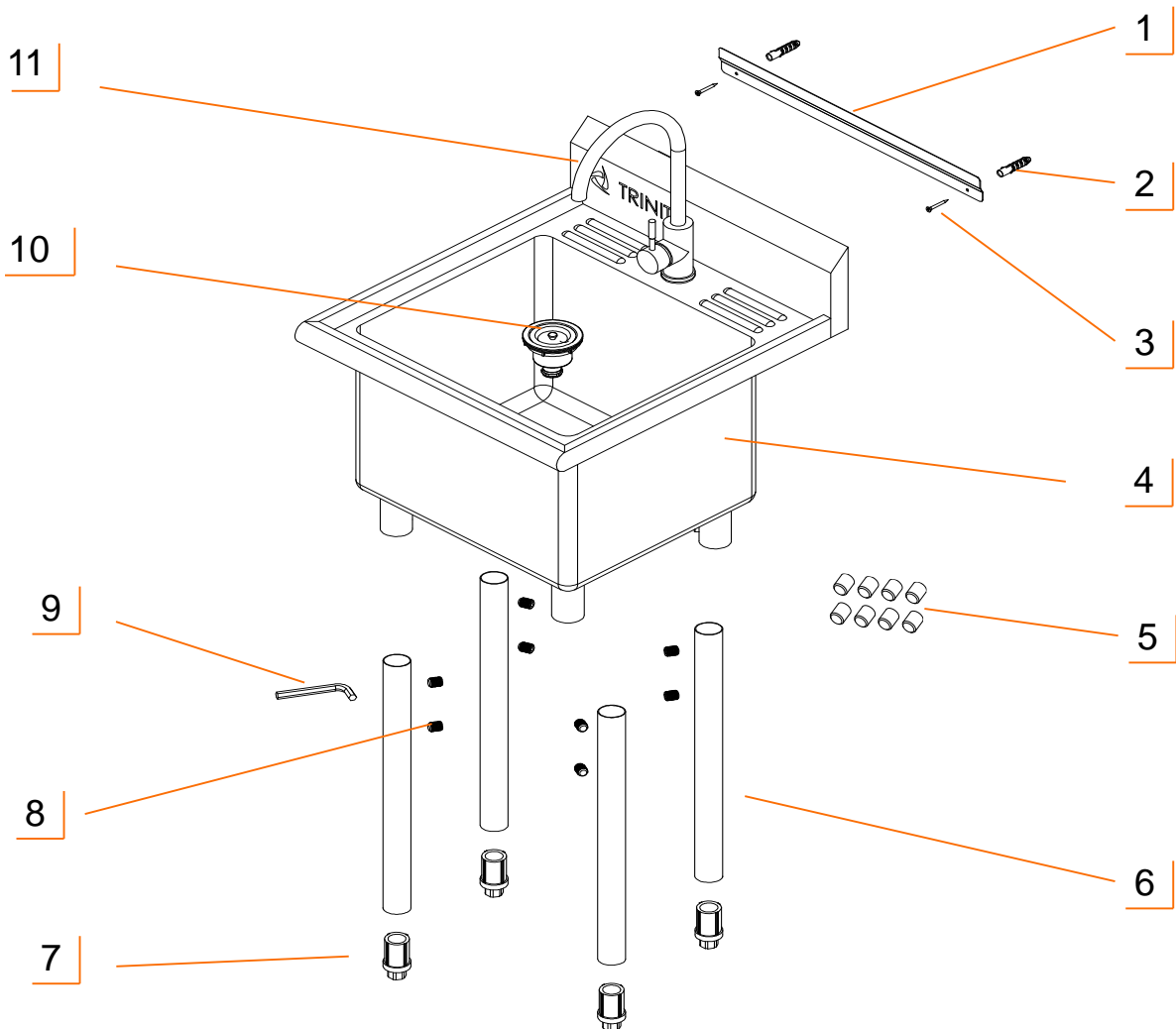

WARNINGS

1. **Read and understand all instructions.** Failure to follow all instructions may result in injury and/or damage.
2. **The warnings, cautions, and instructions discussed in this manual cannot cover all possible conditions or situations that may occur.** The user must always be aware of their environment and ensure that they use the product in a safe and responsible manner.
3. **Do NOT modify the product in any way.** Unauthorized modification may impair the function and/or safety of the product, and may affect the life of the product. Any modifications will void product warranty.
4. **Check for damaged parts.** Before using this product, carefully check that all parts are in good condition, and that the product will operate properly and perform its intended function. Check for damaged parts and any other conditions that may affect the operation of this product. Replace damaged or worn parts, and never use this product with a damaged part.
5. **Do NOT overload the product.**

Total weight capacity	300 lb
-----------------------	--------

6. **Ensure backflow prevention compliance.** Equipment is to be installed with adequate backflow prevention to comply with applicable federal, state and local codes.
7. **Do NOT let children climb on or in Utility Sink.**
8. **Ensure to install the wall bracket.** Failure to do so may result in tipping.
9. **Do NOT mount the sink to a wall without legs.** The wall bracket is to prevent tipping, NOT for mounting the sink to a wall.

CARE AND MAINTENANCE

- Avoid harsh, abrasive cleaners, and other corrosive chemicals. Do not leave salt in sink or near saltwater environment.
- Rinse surface thoroughly with hot water after using soaps and detergents containing chlorides to prevent corrosion.
- Do not use scouring pad, carbon steel brushes, or steel wool for cleaning. Iron particles left behind can lead to rust.
- Avoid the use of oily rags or greasy cloths when wiping the surface. Wipe dry after use so that water does not leave water spots.
- Use a quality stainless steel cleaner and follow instructions that come with the cleaner. Wipe ALONG the grain (NOT against).



PRODUCT REGISTRATION

Thank you for purchasing a TRINITY Basics Stainless Steel Utility Sink w/Faucet. In order to register your product and receive streamlined customer service, please fill out the following Product Registration Form and (1) fax the form to 310.347.4134 (2) complete the Product Registration Form online at www.trinityii.com or (3) scan and email the form to customerservice@trinityii.com. Include a copy of your original receipt with your submission.

First Name: _____ Last Name: _____

Address: _____

City: _____ State: _____ Zip Code: _____

Email Address: _____ Phone: _____

Product Model #: THA-0307 Purchase Date: ____ / ____ / ____

Location of Purchase: _____

Please rate the importance of each feature (1=least important; 10=most important)

Quality ____ Price ____ Size/Capacity ____ Appearance ____ Other ____

How did you hear about our product?

- Magazine Ad Catalog Salesperson Word of Mouth
 Internet Store Display Other

Marital Status: Single Married

Household Income: Below \$50,000 \$50,000-\$150,000 \$150,000+

Education: High School College Graduate School

Primary Residence: Own Rent

Comments/Suggestions:





1 YEAR LIMITED WARRANTY

TRINITY Basics Stainless Steel Utility Sink w/Faucet Model # THA-0307

Trinity International Industries (“Trinity”) warrants to the original consumer purchaser (“Purchaser”) of the TRINITY Basics Stainless Steel Utility Sink w/Faucet (“Product”) that each Product shall be free from defects in workmanship and materials for a period of 1 year from the date of original purchase. Trinity’s obligation under this warranty shall be limited to repair or replacement of, or adequate compensation for the Product which shall not be greater than the amount of the purchase price of the Product, at the option of Trinity, during the warranty period. All replaced parts and Products become the property of Trinity and must be returned to Trinity.

This warranty excludes normal wear and tear of the Product and its parts or components, and damage arising from any of the following: negligent use or misuse of the Product, use contrary to this User’s Manual, or alteration by any one other than Trinity. The warranty period of 1 year shall not be extended or renewed by the repair or replacement of, or compensation for, the Product. Any warranty implied by applicable law is limited in duration to one year from the date of purchase and is subject to the same conditions and limitations as is provided for our express warranty.

Except as set forth herein, and to the extent of applicable there are no warranties on this Product either express or implied, and Trinity disclaims all warranties including, but not limited to, any implied warranties of merchantability, infringement or fitness for a particular purpose. No warranty or guarantee given by any person, firm, or corporation with respect to this product shall be binding on Trinity.

If your Product is defective or otherwise requires service or parts, please call TRINITY Customer Service toll-free at (800) 985-5506, between 5:00 a.m. and 5:00 p.m., PST. Please tell us which model you purchased, the date of the purchase, and the problem with your Product. A copy of your original purchase receipt must accompany your service request.

LIMITATION OF REMEDIES AND LIABILITY

Trinity (and its employees, officers, members, managers, affiliates an assigns) shall not be liable for any incidental, consequential, special, indirect, remote, special or punitive damages for breach of any warranty, express or implied, including, but not limited to, lost profits, lost savings, loss of anticipated benefits and attorneys’ fees, which arise out of the purchase, use or inability to use the Product, whether arising out of contract, negligence, strict tort, product liability, or any other legal theory on which a claim is based. As noted above, to the extent damages are allowed by our express warranty or by applicable law, those damages may not exceed the purchase price paid for the Product. Without limiting the foregoing Purchaser assumes all risk and liability for loss, damage or injury to Purchaser and Purchaser’s property and to others and their property arising out of the use, misuse, or inability to use this Product. This limited warranty shall not extend to anyone other than the original purchaser of this product, is nontransferable and states your exclusive remedy.

Some states do not allow the exclusion or limitation of incidental, consequential, special, or punitive damages, so the above limitation or exclusion may not apply to you. The above warranty gives you specific legal rights, and you may have other rights which vary from state to state.

CONTACT US

**QUESTIONS? NEED PARTS?
WE ARE HERE TO HELP!**

Please feel free to contact us. There are no questions too small, or any problems too big. We're committed to providing our customers with the highest level of service.

TRINITY Customer Service

TEL: 800.985.5506

FAX: 310.347.4134

EMAIL: customerservice@trinityii.com

**Monday through Friday
5:00 AM – 5:00 PM (PST)**

www.trinityii.com